

Threaded Bar Ends Installation Instructions

Thank you for your purchase! We are confident that you will be pleased with the quality of our product.

WARNING! This product will not work with Steel Handlebars or Renthal Twinwall Handlebars.

NOTE:

Tap not included with F.I.T. Handlebar Kits or with Threaded Bar Ends Kit and must be purchased separately.

TAP SIZE: 5/8"-11

Figure A

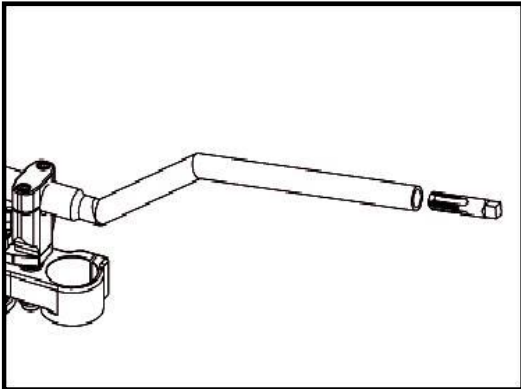

Figure B

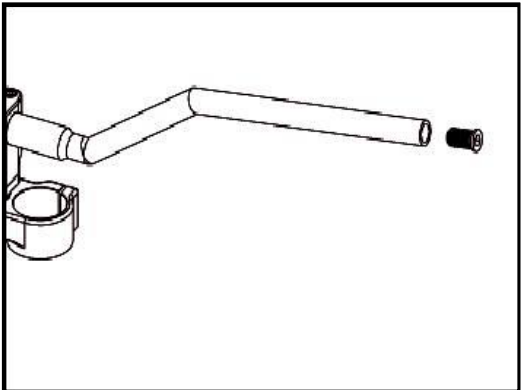
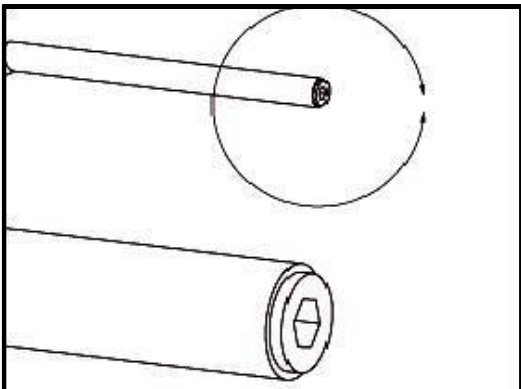

Figure C



1. The ends of the handgrips need to be removed to install the Threaded Bar Ends. Cut away enough to reveal the inner hole of the handlebars. If the throttle tube does not have an open end or a removable end cap, the end will have to be cut off with a hacksaw or trimmed with a razor knife.
2. To thread the inner core of the handle bars, you can leave the bars on the bike or place them in a vice. You will want to remove the chips after tapping the holes using forced air, tipping the bars over, etc.
3. When threading the handlebars, it is important to **make sure that the tap stays true to the centerline of the bars**. Tapping at an angle will cause the fit of the insert to be off and will result in an incorrect installation. (Figure A)
4. Tap the bars by rotating the tap clockwise. Back the tap out frequently to remove chips, about every 1/2 turn. We also recommend using a cutting fluid or light oil (WD-40) to make the job a little easier.
5. After tapping both sides, be sure to remove all chips from the bars, by either tipping them, or blowing them out with air. You are now ready to install the inserts. (Figure B)
6. Install the inserts with an 8mm allen wrench until the inserts are flush with the end of the bars. (Figure C)
7. You are now ready to install your Hanguards. Be sure that your throttle is free and is not obstructed.