

Underbar Mount Instructions-Stock Riser Mount (ASS-DM-0105)

ITEM NO.	PART NUMBER	DESCRIPTION	QTY.
1	LK-PL143_revA	KTM Underbar Mount (stock risers & machined TC)	1
2	VC1-10,9-M10-1,5-60-BLZ	M10 bolt, 60mm long	2

1. Install frame clamp using frame clamp instructions. For this application, the stabilizer must be reverse mounted (Figure 2). To reverse mount the stabilizer; simply reverse the direction of the transfer arm so that it extends back underneath the stabilizer.
2. Remove the stock top handlebar risers (Figure 1). Lay the handlebars on the front fender.
3. Remove the stock handlebar risers.
4. Set the underbar stabilizer mount (Item 1) on the triple-clamp. The open end of the mount should face the back of the bike with the slots on each end facing up.
5. Reinstall the stock handlebar risers using the included M10 bolts (Item 2). Torque the riser to 40 Nm (29.5 lbf*ft)
6. Place the stabilizer on the mount with the transfer arm to the side of the tower pin. Make sure the height of the tower pin is adjusted so that the top of the pin is flush with the top of the transfer arm. **See frame clamp instructions for details.**
7. Insert the tower pin into the slot on the transfer arm and attach the stabilizer to the stabilizer mount using the two M6 bolts included with the stabilizer. **A small amount of semi-permanent thread locking fluid (Blue Loctite #243 or equivalent) should be applied to M6 bolts.**
8. Install handlebars and handlebar top clamps. Torque the top clamp bolts to 20 Nm (14.8 lbf*ft)

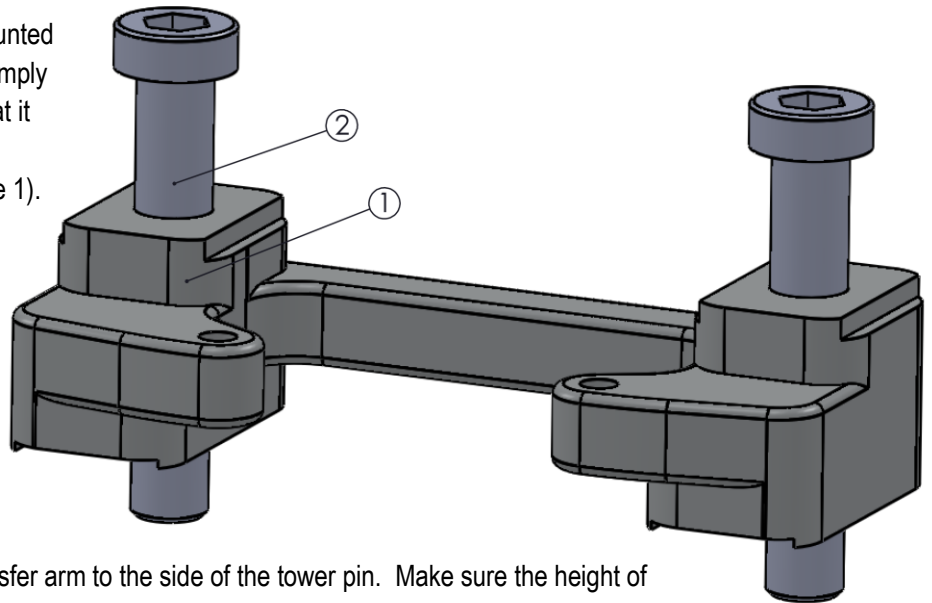

Figure 1



Figure 2

Thanks for purchasing a Fastway steering stabilizer. If you have any questions feel free to give us a call toll free at 866-466-4762 or e-mail sales@promotobillet.com