

Instructions: ASS-DM-0206

1. Install frame clamp using frame clamp instructions.
2. A small amount of semi-permanent thread locking fluid (Blue Loctite #243 or equivalent) should be applied to all fasteners.
3. Remove the stock handlebar risers from the triple clamp.
4. Reinstall triple-clamp; torque the center nut to factory specifications and then torque pinch bolts to factory specifications.
5. Place the 11mm adapters (Item 7) in the holes on the triple clamp. Either the front or back set of holes can be used, but the spacers should use the same set of holes as the handlebar risers.
6. Set the stabilizer mount (Item 1) on the triple clamp. The open end of the mount should face the back of the bike with the slots on each end facing up.
7. Slide the M10 bolts (Item 4) and washers (Item 5) into the triple clamp from the underside.
8. Thread the handlebar risers (Item 2) onto the bolts. The handlebar risers are reversible to allow for two handlebar positions (arrows pointing forward = forward handlebar offset). Ensure that both arrows point in the same direction.
9. Tighten risers from the underside of triple-clamp. (Figure 2)
10. Place the stabilizer on the stabilizer mount with the transfer arm to the side of the tower pin. Adjust the height of the tower pin so that the top of the pin is flush with the top of the transfer arm. **See frame clamp instructions for details.**
11. Insert the tower pin into the slot on the transfer arm and attach the stabilizer to the stabilizer mount using the two M6 bolts included with the stabilizer. (Figure 3)
12. Install handlebars and top clamps (Item 3) using the M8 bolts (Item 6). Make sure to maintain an even gap between the handlebar top clamps and the handlebar risers when tightening bolts.

ITEM NO.	PART NUMBER	DESCRIPTION	QTY.
1	LK-PL138_revA	Underbar Stabilizer Mount	1
2	LK-CL214_revE	Handlebar Riser	2
3	LK-CL232_revB	Handlebar Top Clamp	2
4	RA6-M10.5-M20-2	M10 Washer	2
5	70-2825	M8X25mm Bolt	4
6	LK-SPT119_revA	11mm Adapter	2
7	VCI-10.9-M10-1.5-60-BLZ	M10 bolt, 60mm long	2

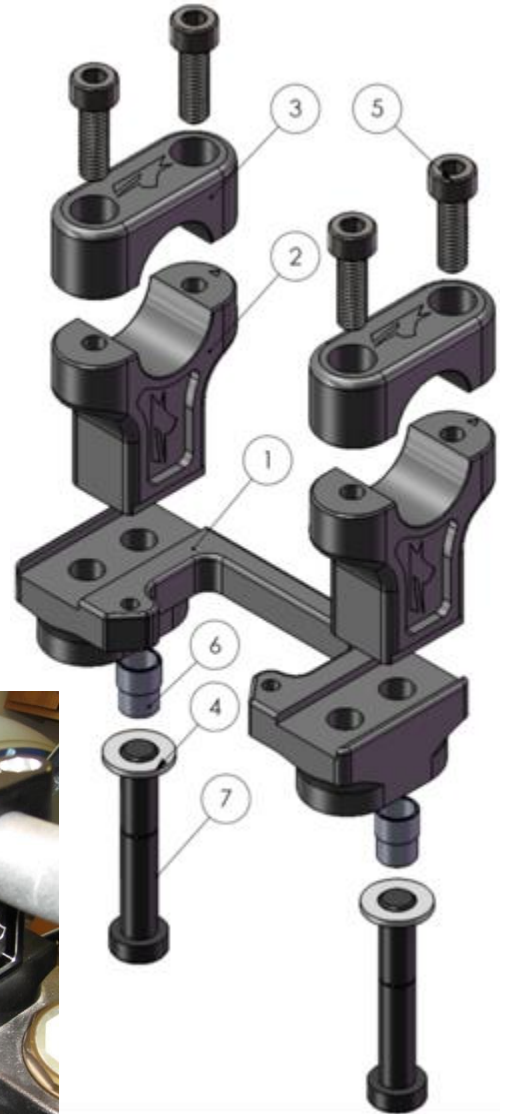

Figure 1

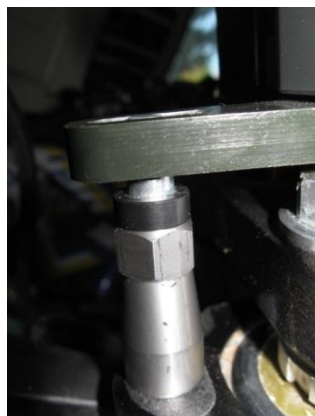

Figure 2



Figure 3

See our entire product line at promotobillet.com