

Instructions: ASS-DM-0401

1. Install frame clamp using frame clamp instructions.
2. **A small amount of semi-permanent thread locking fluid (Blue Loctite #243 or equivalent) should be applied to all fasteners.**
3. Remove the handlebar risers and rubber cones from the underside of the triple-clamp.
4. Reinstall triple-clamp; torque the center nut to factory specifications and then torque pinch bolts to factory specifications.
5. Install the small rubber cones that were included with the frame clamp in the underside of the triple clamp. Slide the M12 x 80mm bolts (Item 5) and M12 washers (Item 6) into the triple clamp from the underside. (Figure 1)
6. Set the underbar stabilizer mount (Item 1) on the triple-clamp. The open end of the mount should face the back of the bike with the slots on each end facing up.
7. Thread the handlebar risers (Item 2) onto the M12 bolts. The risers are reversible to allow for two handlebar positions (arrows pointing forward = forward handlebar offset). Ensure that both arrows point in the same direction.
8. Tighten risers from the underside of triple-clamp.
9. Place the stabilizer on the stabilizer mount with the transfer arm to the side of the tower pin. Make sure the height of the tower pin is adjusted so that the top of the pin is flush with the top of the transfer arm. **See frame clamp instructions for details.**
10. Insert the tower pin into the slot on the transfer arm and attach the stabilizer to the stabilizer mount using the two M6 bolts included with the stabilizer. (Figure 2)
11. Install handlebars and handlebar top clamps (Item 3) using the M8 x 25mm bolts (Item 4). The 1 1/8" to 7/8" adapters (Item 7) are needed for bikes with stock 7/8" handle bars. The gap between the handlebar top clamps and the handlebar risers should be equal from front to back when tightening bolts. (Figure 3)

ITEM NO.	PART NUMBER	DESCRIPTION	QTY.
1	LK-PL117_revB	Underbar Stabilizer Mount	1
2	LK-CL233_revB	Handlebar Riser	2
3	LK-CL232_revB	Handlebar Top Clamp	2
4	70-2825	M8 x 25mm Bolt	4
5	VC1-10.9-M12-1,75-80	M12 x 80mm Bolt	2
6	RA6-M13-M24-2,5	M12 bolt washer	2
7	LK-CL220_revB	1 1/8" to 7/8" Adapter	4

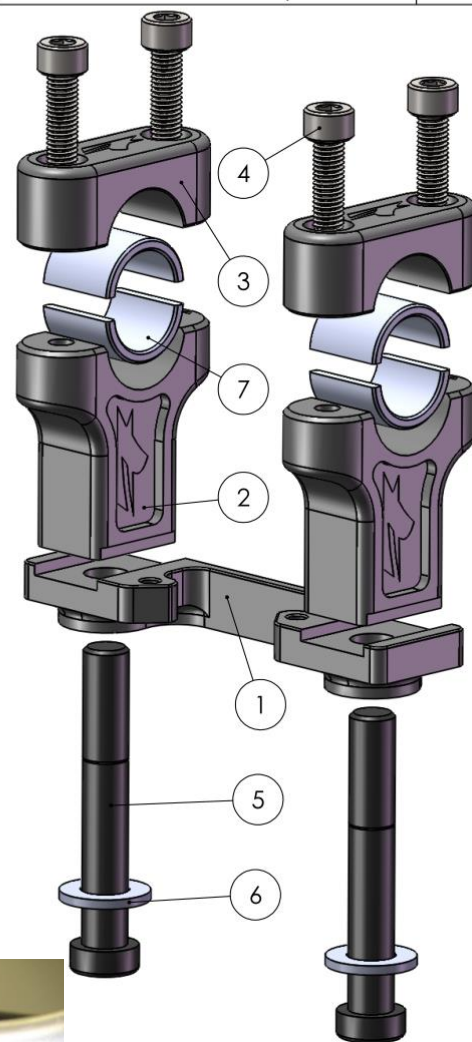

Figure 1



Figure 2



Figure 3

See our entire product line at promotobillet.com