

Instructions: ASS-FC-0106

NOTE: A small amount of semi-permanent thread locking fluid (Blue Loctite #243 or equivalent) should be applied to all fasteners included with stabilizer kit. After a short test ride, check that all bolts are still tight.

1. Place the bike on a stand and secure it to prevent it from falling over during the installation procedure.
2. Slide the transfer arm (Item 1) onto the stabilizer. The arm should fit snugly onto the stabilizer. DO NOT hammer the arm onto the stabilizer. If necessary, rock the arm back and forth into place. Secure the transfer arm to the stabilizer using the M5 bolt (Item 2). Torque to 8 ft-lbs (11 Nm).
3. Remove the handlebar top clamps, handlebar, and stock handlebar risers.
4. Remove the stock dust seal and replace with the new dust seal provided with assembly (removal of the triple clamp might be necessary).
5. Remove the stock aluminum sleeves from the triple clamps. You may need to use a hammer (Figure 5). Put the stock rubber cones on the new sleeves. Install the new sleeves (Item 4).
6. Slide the front half of the frame clamp (Item 5) around the frame and into place (Figure 1). It may be easier to remove the number plate, but it is not necessary.
7. Slide the back half of the frame clamp (Item 5) onto the frame. It may be necessary to hit any high spots in the head tube weld with a file to achieve a quality fit (Figure 2). Alternatively, use a rotary tool to remove material from the frame clamp in the area of weld irregularities.
8. Bolt the two halves of the frame clamp together using the two included M6 bolts (Item 6). Be sure to center the frame clamp as much as possible to the frame. Tighten bolts evenly. Torque to 12 ft-lbs (16 Nm). (Figure 3)
9. Thread the frame clamp tower (Item 7) into the frame clamp and tighten to 40 ft-lbs (54 Nm). (Figure 4)
10. Apply a light coat of grease to the tower pin (Item 8) and slide it into the frame clamp tower. Grease should also be applied to top of tower pin where it inserts into the transfer arm.

ITEM #	PART #	DESCRIPTION	QTY
1	LK-PL073_revB	Transfer Arm	1
2	VC1-10.9-M5-0.8-25-BLZ	M5x0.8x25 Hex Bolt	1
3	70-21025	M10x1.5x25 Socket Bolt	2
4	LK-MS152_revA	Sleeve	2
5	LK-CL262_revA	Frame Clamp	1
6	70-2625	M6x1.0x25 S/S Socket Bolt	2
7A	LK-MS030_revE	Frame Clamp Tower (Underbar)	1
7B	LK-MS040_revB	Frame Clamp Tower (Overbar)	1
8A	LK-PN011_revC	Tower Pin (Underbar)	1
8B	LK-PN012_revC	Tower Pin (Overbar)	1
9	LK-SP090_revA	Aluminum Pin Spacer	2
10	LK-MS024_revA	Dust Seal Cap	1

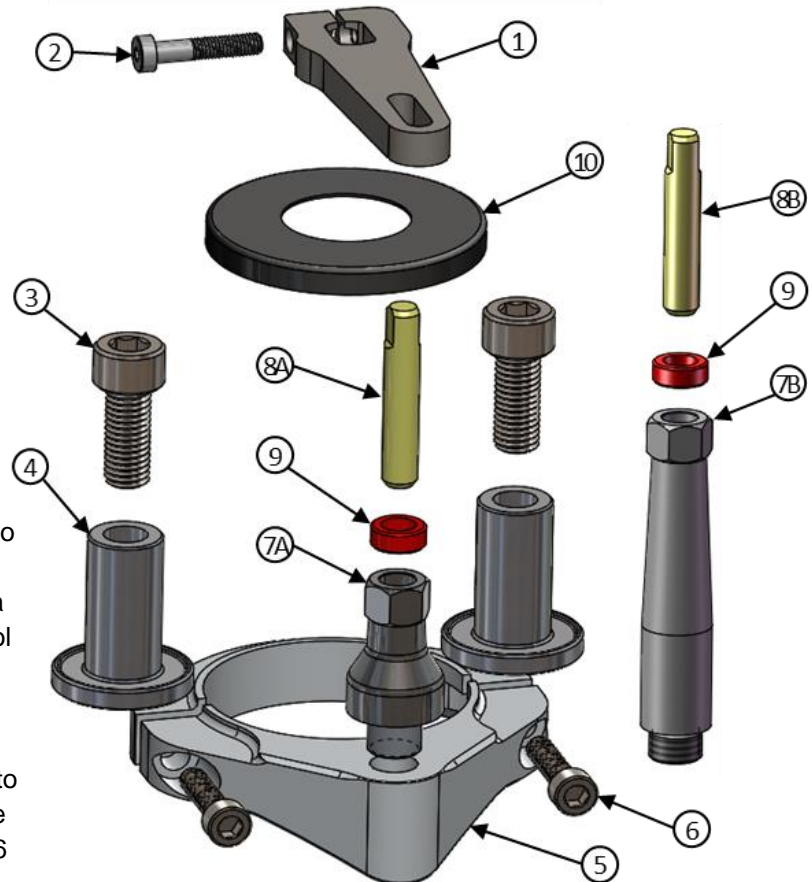

Underbar Stabilizer Installation:

Item 7B used in overbar stabilizer application only.
Stop here and refer to instructions included with underbar mount.



Figure 1



Figure 2

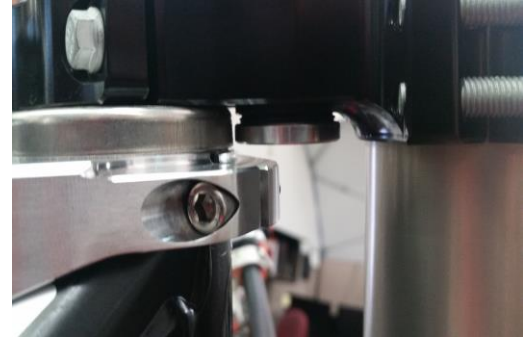

Figure 3

Overbar Stabilizer Installation:

Follow remaining steps.

11. Install the M10 bolts (item 3) through the stock under-bar plate and triple clamp into the new sleeves (item 4)
12. Install handlebars and overbar mount. Make sure to maintain an even gap between the overbar mount and the handlebar risers when tightening bolts. Torque all four bolts evenly to 25 ft-lbs (34 Nm) using an "X" pattern.
13. The overbar mount includes a sliding plate. Adjust the sliding plate so that the stabilizer knobs are centered over the center nut on the triple clamp. Torque the sliding plate bolts to 8 ft-lbs (11 Nm). Set the stabilizer onto the mount with the tower pin in the slot on the transfer arm and secure the stabilizer to the mount with the 2 M6 bolts included with the stabilizer. Torque both bolts to 12 ft-lbs (16 Nm).
14. **The aluminum spacer (Item 8) on the tower pin is adjustable!** Gently tap on the top of the pin with a hammer to adjust height. The top of the tower pin should be flush with the top of the transfer arm (Figure 6).
15. **Turn the handle bars in both directions and verify that the bars turn to the steering stops. If not, remove the stabilizer from the overbar mount and move the sliding plate forward about 1/8". Reinstall the stabilizer and re-check the steering movement. Repeat if necessary until the handlebar turns to the steering stops in both directions.**



Figure 4



Figure 5



Figure 6

See our entire product line at promotobillet.com