

Instructions: ASS-FC-0204

1. Place the bike on a stand and secure it to prevent it from falling over during the installation procedure.

2. **A small amount of semi-permanent thread locking fluid (Blue Loctite #243 or equivalent) should be applied to all fasteners included with stabilizer kit. After a short test ride, check that all bolts are still tight.**

3. Slide the transfer arm (Item 7) onto the stabilizer. The arm should fit snugly onto the stabilizer. **DO NOT** hammer the arm onto the stabilizer. If necessary, rock the arm back and forth into place. Secure the transfer arm to the stabilizer using the M5 bolt (Item 8).

4. Remove the number plate and set it aside.

5. **Underbar Mount Only:** Remove the 2 nuts under the triple-clamp that hold the handlebar clamps. (Figure 1)

6. Remove the top handlebar clamps and lay the handlebars on the front fender.

7. Remove triple-clamp by loosening the two pinch bolts on each side and removing the center nut.

8. Remove the fuel tank tab bolt and the plastic radiator shroud. Lift up the fuel tank and remove the stock fuel tank tab. Install the new fuel tank tab (Item 5) using the stock hardware. (Not needed on WR450)

9. Attach the frame clamp tab (Item 2) to the frame clamp (Item 1) using the M5x10mm bolts (Item 4)

10. Gently spread the frame clamp by sliding a flat screwdriver into the slot at the front of the clamp. With the clamp spread apart, slide it down onto the frame. Ensure that the frame clamp is fully seated on the frame. (Figure 2)

11. Reinstall the fuel tank tab bolt. Secure the frame clamp using the M6 bolt (Item 3). Ensure that the frame clamp does not slide up on the frame when tightening.

12. Slide the triple clamp spacer (Item 6) over the steering stem. (Figure 3)

13. Thread the frame clamp tower (Item 10) into the frame clamp and tighten. Don't forget to use thread locking fluid on the tower threads.

14. Reinstall the plastic radiator shrouds.

ITEM NO.	PART NUMBER	DESCRIPTION	QTY.
1	LK-CL238_revA	Frame Clamp	1
2	LK-CL238-TAB_revA	Frame Clamp Tab	1
3	70-2625	M6X25mm Bolt	1
4	70-1510	M5X10mm Bolt	2
5	LK-PL142_revA	Fuel Tank Tab	1
6	LK-SP092_revA	Triple clamp spacer	1
7	LK-PL005_revA	Transfer Arm	1
8	VC1-10,9-M5-0,8-25-BLZ	M5 bolt, 25mm long (1")	1
9	LK-SP090_revA	Aluminum Pin Spacer	1
10a	LK-MS030_revE	Frame Clamp Tower (Underbar)	1
11a	LK-PN011_revC	Tower Pin (Underbar)	1
10b	LK-MS040_revB	Frame Clamp Tower (Overbar)	1
11b	LK-PN012_revC	Tower Pin (Overbar)	1

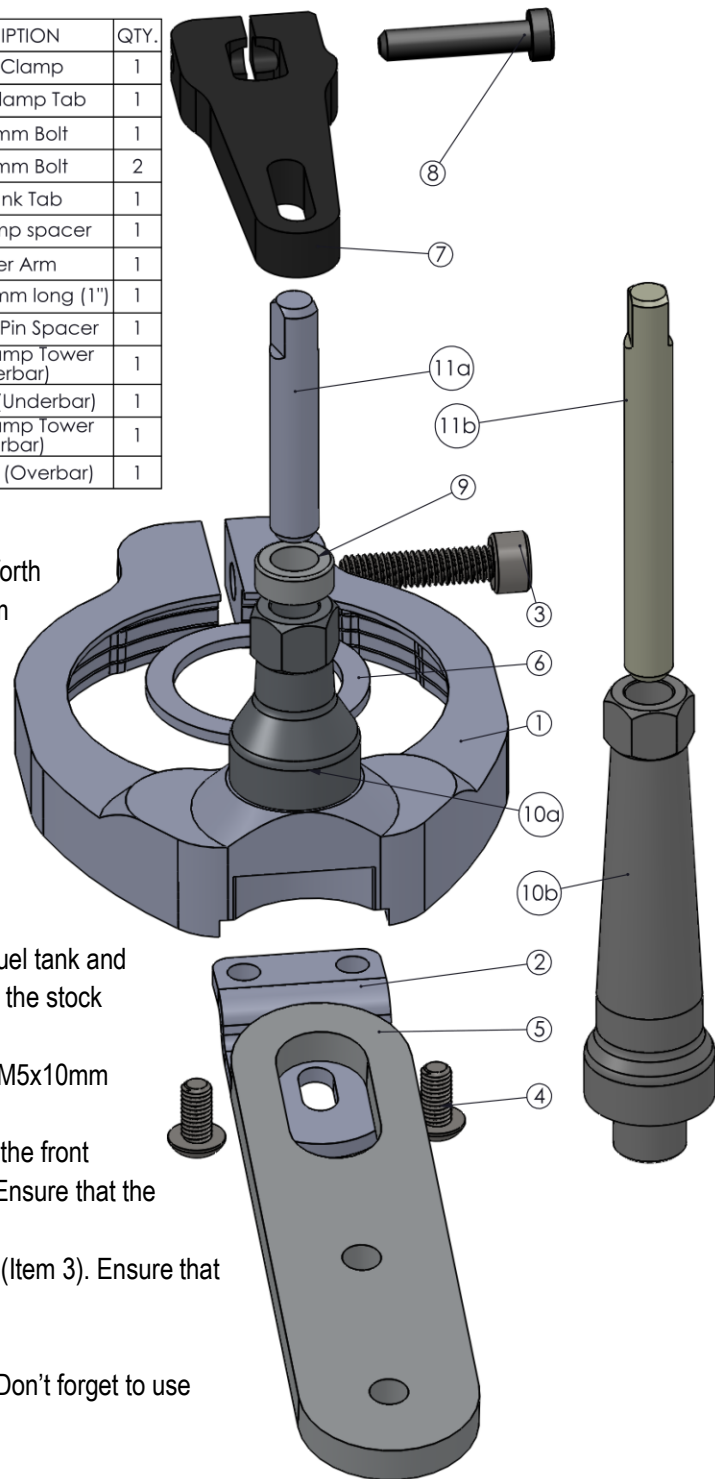



Figure 1: UNDERBAR MOUNT ONLY



Figure 2



Figure 3

15. Apply a light coat of grease to the tower pin (Item 11) and slide it into the frame clamp tower. Grease should also be applied to top of tower pin where it inserts into the transfer arm.

The aluminum spacer (Item 9) on the tower pin is adjustable! Gently tap on the top of the pin with a hammer to adjust height. The top of the tower pin should be flush with the top of the transfer arm. (Figures 4 & 5)

Underbar Stabilizer Installation:

Stop here and refer to instructions included with underbar mount for reassembly.

Overbar Stabilizer Installation:

Follow remaining steps.

16. Reinstall triple-clamp; torque the center nut to factory specifications and then torque pinch bolts to factory specifications.
17. Install handlebars and overbar mount. Make sure to maintain an even gap between the overbar mount and the handlebar risers when tightening bolts.
18. The overbar mount includes a sliding plate. Adjust the sliding plate so that the stabilizer knobs are centered over the center nut on the triple clamp. Set the stabilizer onto the mount with the tower pin in the slot on the transfer arm and secure the stabilizer to the mount with the 2 M6 bolts included with the stabilizer.
19. **Turn the handlebars both directions and verify that the bars turn to the steering stops. If not, remove the stabilizer from the overbar mount and move the sliding plate forward about 1/8". Reinstall the stabilizer and re-check the steering movement. Repeat if necessary until the handlebar turns to the steering stops in both directions.**
20. Installation is now complete. Check the tightness of bolts regularly and enjoy your new Fastway steering stabilizer!



Figure 4



Figure 5

See our entire product line at promotobillet.com