

# Instructions: ASS-FC-0207

**NOTE: Must file down one spot on frame of 2018 YZ450F. See figure 9 for details**

ITEM #	PART #	DESCRIPTION	QTY
1	LK-CL258_revA	2014 YZ450F Frame Clamp	1
2	LK-SP124_revA	Triple Clamp Spacer	1
3a	LK-MS049_revB	Frame Clamp Tower (Overbar)	1
3b	LK-MS030_revE	Frame Clamp Tower (Underbar)	1
4	LK-PL005_revB	Control arm 71mm	1
5a	LK-PN012_revC	Tower Pin (Overbar)	1
5b	LK-PN011_revC	Tower Pin (Underbar)	1
6	70-2620	BOLT M6X20 SOCKET S/S	1
7	VC1-10.9-M5-0.8-25-BLZ	M5 bolt, 25mm long (1")	1
8	LK-SP090_revA	Aluminum Pin Spacer	1

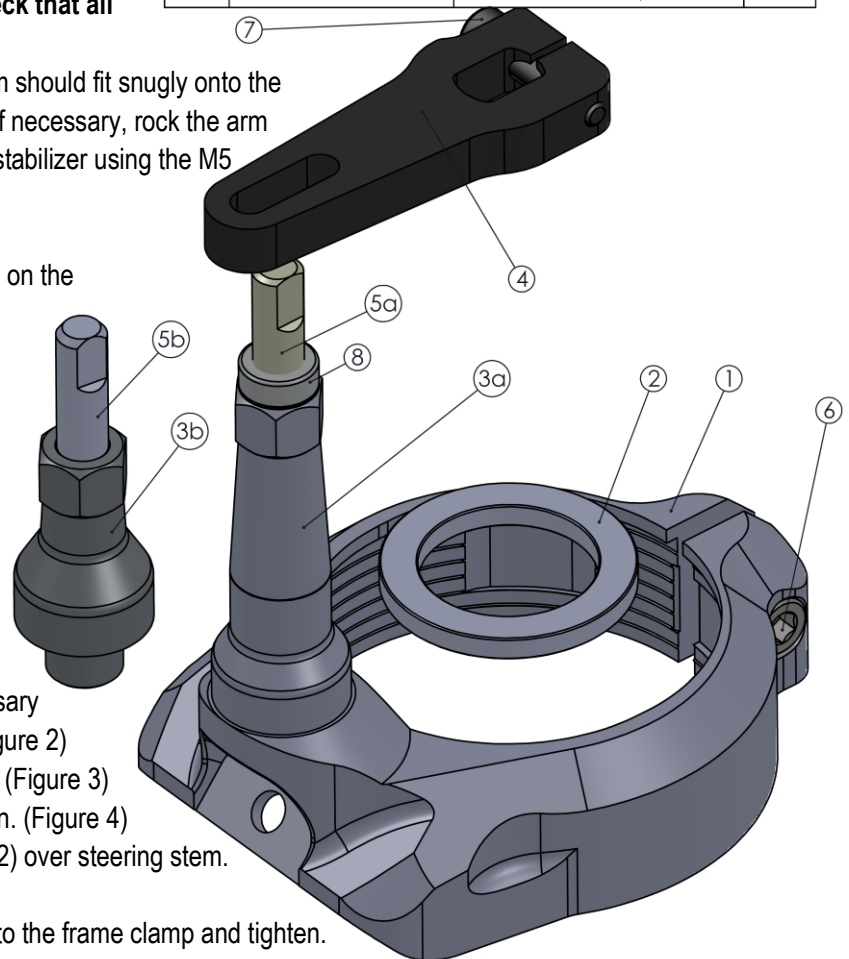

- Place the bike on a stand and secure it to prevent it from falling over during the installation procedure.
- A small amount of semi-permanent thread locking fluid (Blue Loctite #243 or equivalent) should be applied to all fasteners included with stabilizer kit. After a short test ride, check that all bolts are tight.**
- Slide the transfer arm (Item 4) onto the stabilizer. The arm should fit snugly onto the stabilizer. **DO NOT** hammer the arm onto the stabilizer. If necessary, rock the arm back and forth into place. Secure the transfer arm to the stabilizer using the M5 bolt (Item 7).
- Remove the number plate and set it aside.
- Remove the handlebar top clamps and lay the handlebars on the front fender.
- Overbar Installation Skip This Step:** Loosen the 2 nuts under the triple-clamp that hold the handlebar risers.
- Remove triple-clamp by loosening the two pinch bolts on each side and removing the center nut. (Figure 1)
- Remove the bolt securing front of the air box to the frame.
- Gently spread the frame clamp (Item 1) by sliding a flat screwdriver into the slot at the front of the clamp. With the clamp spread apart, slide it down onto the frame. Air box tab fits into the recess of the frame clamp; be sure frame clamp is fully seated on the frame. It may be necessary to tap the frame clamp into place with a rubber mallet. (Figure 2)
- Attach and tighten the front of the air box using stock bolt. (Figure 3)
- Insert the M6 bolt (Item 6) into the frame clamp and tighten. (Figure 4)
- Replace stock triple clamp spacer with thick spacer (Item 2) over steering stem. (Figure 5)
- Apply loctite and thread the frame clamp tower (Item 3) into the frame clamp and tighten. (Figure 6)
- Apply a light coat of grease to the tower pin (Item 5) and slide it into the frame clamp tower. Grease should also be applied to the flat sections near the top of the tower pin where it inserts into the transfer arm. **The aluminum spacer (Item 8) on the tower pin is adjustable!** Gently tap on the top of the pin with a hammer to adjust height. The top of the tower pin should be flush with the top of the transfer arm. (Figures 7 & 8)
- Underbar Stabilizer Installation:** Stop here and refer to instructions included with underbar mount for reassembly.
- Overbar Stabilizer Installation:** Follow remaining steps.
- Reinstall triple-clamp; torque the center nut to factory specifications and then torque pinch bolts to factory specifications.
- Install handlebars and overbar mount. Make sure to maintain an even gap between the overbar mount and the handlebar risers when tightening bolts.
- The overbar mount includes a sliding plate. Adjust the sliding plate so that the stabilizer knobs are centered over the center nut on the triple clamp. Set the stabilizer onto the mount with the tower pin in the slot on the transfer arm and secure the stabilizer to the mount with the two M6 bolts included with the stabilizer.

20. Turn the handlebars both directions and verify that the bars turn to the steering stops. If not, remove the stabilizer from the overbar mount and move the sliding plate forward about 1/8". Reinstall the stabilizer and re-check the steering movement. Repeat if necessary until the handlebar turn to the steering stops in both directions. Installation is now complete! Check tightness of bolts often.



Figure 1



Figure 2



Figure 3



Figure 4



Figure 5



Figure 6



Figure 7



Figure 8



This is the spot that needs to be filed down

Figure 9

See our entire product line at [promotobillet.com](http://promotobillet.com)