

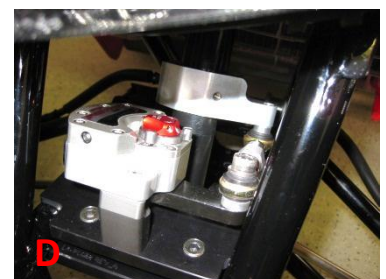

2006-2013 Honda TRX450R Stabilizer Mounting Instruction ASV-LM-0809

1. A small amount of semi-permanent thread locking fluid (Blue Loctite #243 or equivalent) should be applied to all fasteners included with stabilizer kit. After a short first ride, check that all bolts are still tight.
2. Install both heim joints (Items# 8 and 9) into the Damper Arm Link (Item# 6) making sure to include the Jam Nuts (Items# 12 and 13). The side of the damper arm link with the groove has left handed threads.
3. Install the Damper Arm Link onto the Steering Stem Clamp using one M8x35 bolt (Item# 16), a link arm spacer (Item# 5), 8mm washer (Item# 11), and Heim Joint Covers (Item# 7). (Picture A)
4. Install Steering Stem Clamp on steering stem as shown using the associated four bolts and set screw. (Picture B)
Helpful Tip: Spin backwards, install bolts lightly, then spin clamp 180° into position. The goal is to get the vehicle's wheels pointing straight with the steering stem clamp perpendicular to front wheels.
5. Bolt the Damper Mounting Spacer (Item# 4) to the Upper Mounting Plate (Item# 2) using three M6x16 bolts (Item# 10).
6. Place Damper Mounting Spacer and Upper Mounting Plate onto frame rails as shown. (Picture C)
7. Loosely install the Lower Mounting Plate and bolt to Upper Mounting Plate using four M8x35 bolts (Item# 16). Adjust as necessary and check that the plate clears any frame welds.
8. Install Transfer Arm (Item# 1) onto Steering Stabilizer using the M5 bolt (Item# 14).
9. Install Stabilizer onto Damper Mounting Spacer using two M6x16 bolts. (Provided with your stabilizer)
10. Install the Damper Arm Link to the Transfer Arm with a spacer in between using one M8x30 bolt (Item# 15), an M8 washer (Item# 11), and two heim joint covers (Item# 7).
11. Center and tighten the Steering Stem Clamp and set screw. Verify that the steering stem, damper arm link, and transfer arm are all set perpendicular to each other when the front wheels are pointed straight. (Picture D)
12. Check all bolts; ensure steering travel hasn't been compromised. Make sure all components clear brake lines and other stock parts.

ITEM NO.	PART NUMBER	DESCRIPTION	QTY.
1	LK-PL010_revF	Control Arm ATV	1
2	LK-PL021_revB	Upper Mounting Plate / TRX450 06	1
3	LK-PL022_revA	Lower Mounting Plate / TRX450 06	1
4	LK-PL013_revD	Damper mounting spacer	1
5	LK-SP062_revB	Link Arm Spacer	2
6	LK-TG038_revE	Damper Arm Link 34mm	1
7	LK-MS150	Heim Joint Cover	4
8	POS8-M	M8x1.25 Modified Heim Joint	1
9	POS8L-M	M8x1.25 Modified LH Heim Joint	1
10	70-2616	BOLT M6X16 SOCKET S/S	3
11	70-6008	Washer M8 Flat S/S	2
12	70-5018	M8x1.25 Jam Nut	1
13	70-5018L	M8x1.25 Left Hand Jam Nut	1
14	VC1-10.9-M5-0.8-25-BLZ	M5 bolt, 25mm long (1")	1
15	VB1-12.9-M8-1.25-30-BLZ	BOLT M8X30 SOCKET	1
16	VB1-12.9-M8-1.25-35-BLZ	M8 bolt, 35mm long (1-3/8")	5

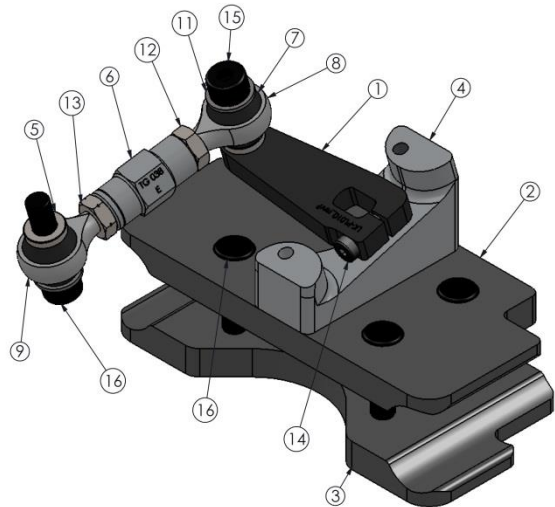

Thanks for purchasing a Fastway steering stabilizer. If you have any questions feel free to give us a call toll free at 866-466-4762 or e-mail sales@promotobillet.com