

Yamaha Raptor 660 Stabilizer Mounting Instructions ASV-LM-0817

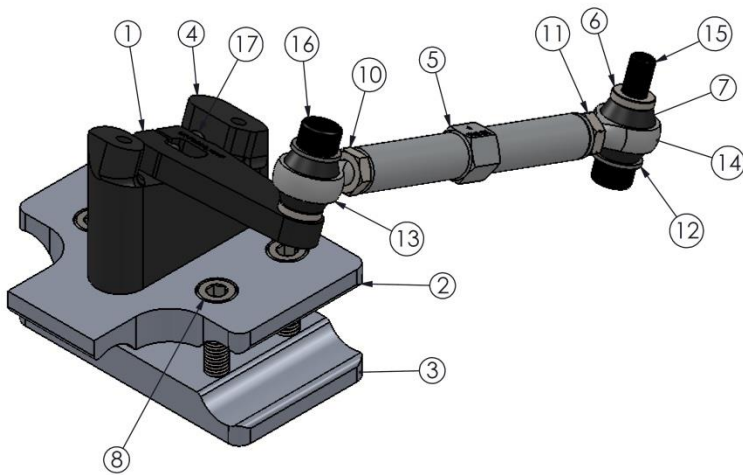

ITEM NO.	PART NUMBER	DESCRIPTION	QTY.
1	LK-PL010_revF	Control Arm ATV	1
2	LK-PL054_revA	Upper Mounting plate / Raptor660	1
3	LK-PL055_revA	Lower Mounting plate / Raptor660	1
4	LK-PL080_revA	Mounting Spacer Damper	1
5	LK-TG046_revF	Damper Arm Link 105mm	1
6	LK-SP062_revB	Link Arm Spacer	2
7	LK-MS150	Heim Joint Cover	4
8	70-2835	BOLT M8X35 SOCKET S/S	4
9	70-2820	BOLT M8X20 SOCKET S/S	3
10	70-5018	M8x1.25 Jam Nut	1
11	70-5018L	M8x1.25 Left Hand Jam Nut	1
12	70-6008	Washer M8 Flat S/S	2
13	POS8	M8x1.5 Heim Joint	1
14	POS8L	M8x1.25 Left Hand Heim Joint	1
15	VB1-12,9-M8-1,25-35-BLZ	M8 bolt, 35mm long (1-3/8")	1
16	VB1-12,9-M8-1,25-30-BLZ	BOLT M8x30 SOCKET	1
17	VC1-10,9-M5-0,8-25-BLZ	M5 bolt, 25mm long (1")	1

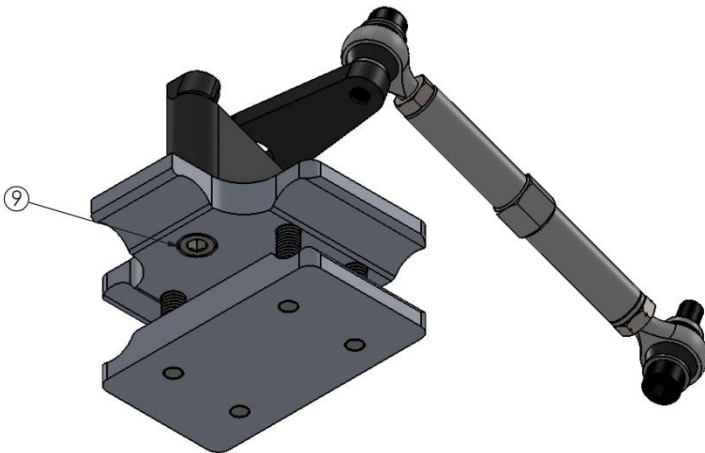

1. A small amount of semi-permanent thread locking fluid (Blue Loctite #243 or equivalent) should be applied to all fasteners included with the stabilizer kit. After a short first ride, check that all bolts are still tight.
2. Install both heim joints (Items# 13 and 14) into the Damper Arm Link (Item# 5) making sure to include the Jam Nuts (Items# 10 and 11). The side of the damper arm link with the groove has left handed threads. The jam nut with grooved edges is also left hand threaded. (Picture A)
3. Install the Damper Arm Link (Item# 5) onto the Steering Stem Clamp using one 35mm long M8 bolt (Item# 15), a link arm spacer (Item# 6), 8mm washer (Item# 12), and two Heim Joint Covers (Item# 7). (Picture A)
4. Install the Steering Stem Clamp onto the steering stem as shown using the associated four bolts and set screw. (Picture B)

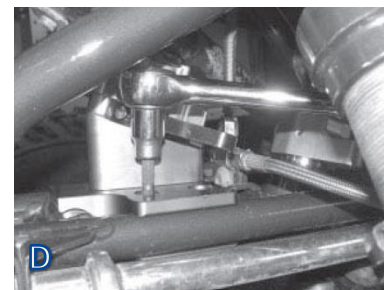
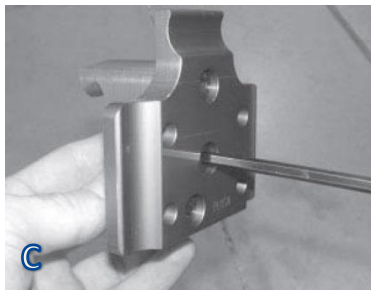

Helpful Tip: Spin clamp backwards, install bolts lightly, then spin clamp 180° into position. The goal is to get the vehicle's wheels pointing straight with the steering stem clamp aligned perpendicular to front wheels.

5. Bolt the Damper Mounting Spacer (Item# 4) to the Top Mounting Plate (Item# 2) using three 20mm long M8 bolts (Item# 9). (Picture C)
6. Place Damper Mounting Spacer and Top Mounting Plate onto frame rails as shown. (Picture D)
7. Loosely install the Lower Mounting Plate (Item# 3) using the four M8x35 bolts (Item# 8).
8. Install Control Arm (Item# 1) onto the Steering Stabilizer using the M5 bolt (Item# 17). (Picture E and F)
9. Mount the Steering Stabilizer onto the Damper Mounting Spacer using the two M6 bolts provided with your stabilizer. (Picture G)
10. Connect the Damper Arm Link to the Control Arm with the 30mm M8 bolt (Item# 16), two heim joint covers (Item# 7), a link arm spacer (Item# 6), and an 8mm washer (Item# 12).
11. With the front wheels and handlebars set straight, make sure that the clamp on the steering stem, the damper arm link, and the transfer arm of the unit are all set to 90 degrees from each other. Refer to the Installation verification procedure.
12. Once all components are in their proper locations, tighten and check all bolts.
13. Re-Install the radiator and plastic nosepiece and front fenders.
14. With the fasteners secure, ensure that steering travel hasn't been compromised. Check that all brake lines, wiring, and other stock components are free as well.

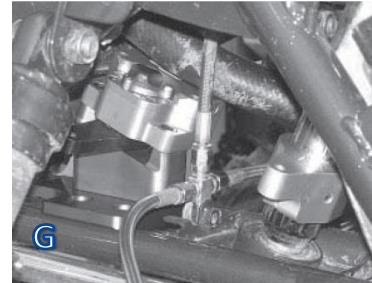

Thanks for purchasing a Fastway steering stabilizer. If you have any questions feel free to give us a call toll free at 866-466-4762 or e-mail sales@promotobillet.com