

1. Place ATV on a stand so front tires can be turned back and forth freely.
2. **A small amount of semi-permanent thread locking fluid (Blue Loctite #243 or equivalent) should be applied to all fasteners included with stabilizer kit. After a short first ride, check that all bolts are still tight.**
3. Remove upper headlight shroud. (Picture A)
4. Remove headlight assembly. (Picture B)
5. Remove six bolts holding the fenders on.
6. Remove the front fenders.
7. Unbolt the Regulator/Rectifier and gently set aside out of the way while the damper is installed. (Pictures C & D)
8. Remove brake line mount located directly behind the steering stem. (Picture E)

9. Install Brake Line Relocating Bracket (Item# 8). Use the stock bolts for mounting. (Picture F)
10. Install Connecting Shaft (Item# 11) onto the Steering Stem Clamp using one M8x35 bolt (Item# 17), spacer (Item# 15), washer (Item# 14), and Heim Joint Covers (Item# 10). (Picture G)
11. Install Steering Stem Clamp on steering stem as shown using the associated four bolts and set screw. (Picture H)

Helpful Tip: Spin backwards, install bolts lightly, then spin clamp 180° into position. The goal is to get the vehicle's wheels pointing straight with the steering stem clamp perpendicular to front wheels.

12. Bolt the Damper Mounting Spacer (Item# 3) to the Upper Mounting Plate (Item# 2) using three 16mm long M6 bolts (Item# 5).
13. Place Damper Mounting Spacer and Upper Mounting Plate onto frame rails as shown. (Picture I)
14. Loosely install the Lower Mounting Plate (Item# 1) and bolt to Upper Mounting Plate using four M8 bolts (Item# 4). Adjust as necessary and check that the plate clears the welds. As a starting point, position the upper mounting plate 0.55" behind the front frame cross member as shown (Pictures J & K).

ITEM NO.	PART NUMBER	DESCRIPTION	QTY
1	LK-PL147_revA	Lower Mounting Plate / TRX700 08-09	1
2	LK-PL146_revA	Upper Mounting Plate / TRX700 08-09	1
3	LK-PL013_revD	Damper mounting spacer	1
4	70-2835	BOLT M8X35 SOCKET S/S	4
5	70-2616	BOLT M6X16 SOCKET S/S	3
6	LK-PL010_revF	Control Arm ATV	1
7	VC1-10,9-M5-0,8-25-BLZ	M5 bolt, 25mm long (1")	1
8	LK-PL145_revA	Honda TRX700 08-09 Brake Junction Bracket	1
9	LK-PL144_revA	Honda TRX700 08-09 Reg/Rect Bracket	1
10	LK-MS150	Heim Joint Cover	4
11	LK-TG038_revE	Damper Arm Link 34mm	1
12	POS8L-M	M8x1.25 Modified LH Heim Joint	1
13	POS8-M	M8x1.25 Modified Heim Joint	1
14	70-6008	WASHER M8 FLAT S/S	2
15	LK-SP062_revB	Link Arm Spacer	2
16	VB1-12,9-M8-1,25-30-BLZ	BOLT M8x30 SOCKET	1
17	VB1-12,9-M8-1,25-35-BLZ	M8 bolt, 35mm long (1-3/8")	1
18	70-5018	M8x1.25 Jam Nut	1
19	70-5018L	M8x1.25 Left Hand Jam Nut	1
20	70-6006	WASHER M6 FLAT S/S	2
21	70-2620	BOLT M6X20 SOCKET S/S	2

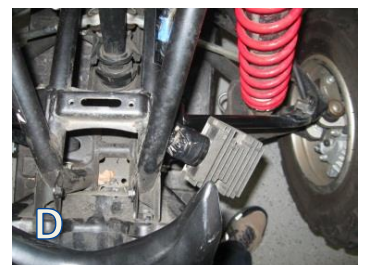
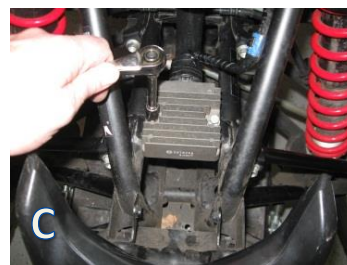
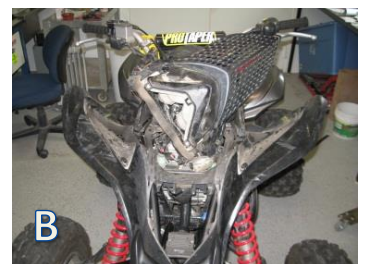
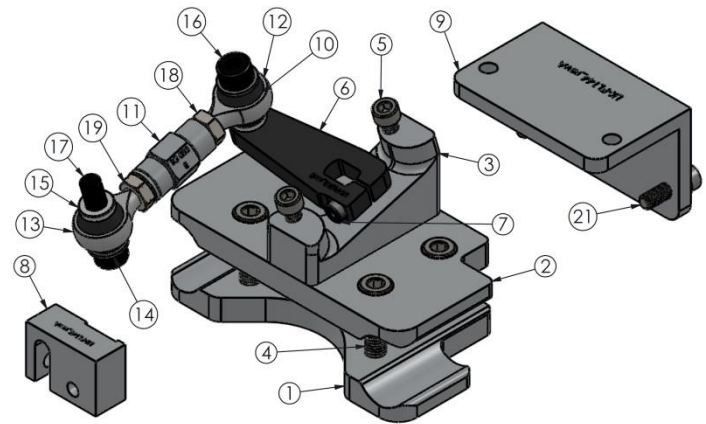

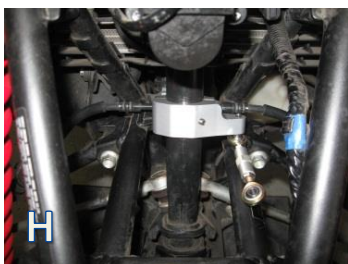

15. Install Transfer Arm (Item#6) onto Steering Stabilizer using the M5x25 bolt (Item# 7).
16. Install Stabilizer onto Damper Mounting Spacer using two M6x16 bolts.
17. Install Connecting Shaft to the Transfer Arm with a spacer in between using one 30mm long M8 bolt.
18. Center and tighten the Steering Stem Clamp and set screws. Verify that the steering stem, connecting rod, and transfer arm are all set perpendicular to each other when the handlebars and front wheels are set straight. (Additional sheet provided)
19. Install Regulator/Rectifier Relocating Bracket (Item# 9) and Regulator/Rectifier onto threaded holes with two M6x20 bolts and washers (Item# 20 & 21). (Picture L)
20. Check all bolts; ensure steering travel hasn't been compromised. Make sure all components clear brake lines and other stock parts.
21. Reassemble stock fenders.

*Make sure there is no interference or contact between the steering damper's moving parts and other components when the handlebars are turned completely on either side. Also, make sure there is no interference or contact between the connecting shaft and the steering stem when the handlebars are turned completely on either side.

Thanks for purchasing a Fastway Steering Stabilizer. If you have any questions feel free to give us a call toll free at 866-466-4762 or e-mail sales@promotobillet.com